

THIS COPY IS PROVIDED ON A RESTRICTED BASIS AND IS NOT TO BE USED IN ANY WAY DETRIMENTAL TO THE INTERESTS OF PANDUIT CORP.

PANDUIT PART NUMBER	STUD SIZE	DIMENSIONS in.				
		A $\pm .030$	W $\pm .010$	C $\pm .020$	M $\pm .030$	H $\pm .010$
PNF14-6LF-3K	#6	.85 (21.59)	.25 (6.35)	.18 (4.57)	.63 (16.00)	.14 (3.56)
PNF14-6LFW-3K	#6	.85 (21.59)	.29 (7.37)	.18 (4.57)	.63 (16.00)	.14 (3.56)
PNF14-8LF-3K	#8	.92 (23.37)	.29 (7.37)	.23 (5.84)	.68 (17.27)	.16 (4.06)
PNF14-10LF-3K	#10	.92 (23.37)	.33 (8.38)	.23 (5.84)	.68 (17.27)	.19 (4.83)
PNF14-10LFN-3K	#10	.92 (23.37)	.28 (7.11)	.23 (5.84)	.68 (17.27)	.19 (4.83)

NOTES :

- UL LISTED AND CSA CERTIFIED FOR :
 A. 600 V MAX. VOLTAGE RATING
 B. 221°F (105°C) MAX. TEMP. RATING
 C. #16-14 AWG (1.5-2.5 mm²) SOLID OR STRANDED, COPPER WIRE
- PACKAGE QTY. : 3K = 3000 PCS.
CONTINUOUS MOLDED CARRIER STRIP
- MATERIAL :
 A. STAMPING - .03" THK COPPER, TIN PLATED
 B. HOUSING - BLUE NYLON
 C. SLEEVE - BRASS, TIN PLATED
- DIMENSIONS IN BRACKETS ARE IN MILLIMETERS
- INSTALLATION TOOLS :
 A. PRESSES - CP-851, CP-860, CP-861
 B. APPLICATOR - CA-800
 C. DIE INSERTS - CD-800-2
- WIRE STRIP LENGTH: $1/4^{+1/32}_{-0}$ (6.4^{+0.8}₋₀)

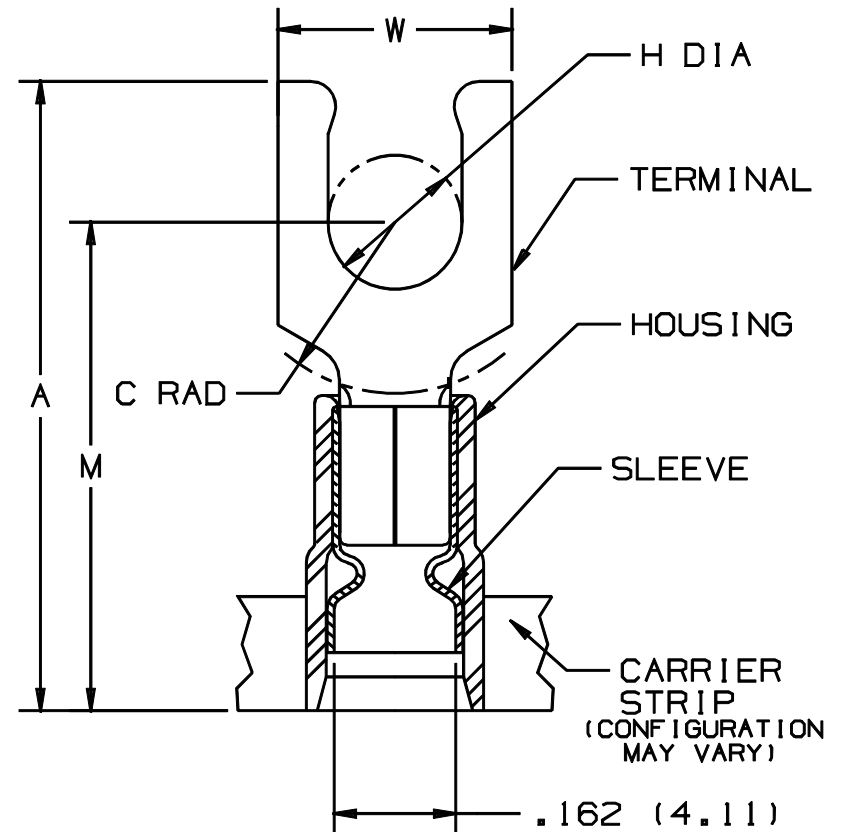

.162 (4.11)
MAX WIRE
INSUL DIA
.080 (2.03)
MIN. WIRE
INSUL. DIA.



LISTED
587H
E52164



CERTIFIED
LR31212

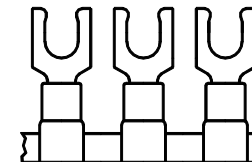

04	1/01	KMD		CAD FILE SPEC. WAS N41147A_PCD_03				
03	1/97	JAMB		ADDED DIM., "MIN. WIRE INSULATION DIA."	05410			
02	9/96	TSMARLS		REVISE TOLERANCES, ADD NOTE #6	05086	LA	DRH	
				ORIGINAL FILESPEC WAS A41147A				
1	3/88	GM		REDRAWN WITH REVISIONS		LA	KS	
REV	DATE	BY	CHK	DESCRIPTION	ECN	QA	CUST	PM

A41147_04

PANDUIT CORP.

TINLEY PARK, ILLINOIS

TERMO 3PC. CONTINUOUSLY MOLDED NYLON (FUNNEL)
INSULATED, 16-14 BARREL, LOCKING FORKS

DRAWN BY GRM Ck'D FS SCALE NONE DRAWING NO. A41147